

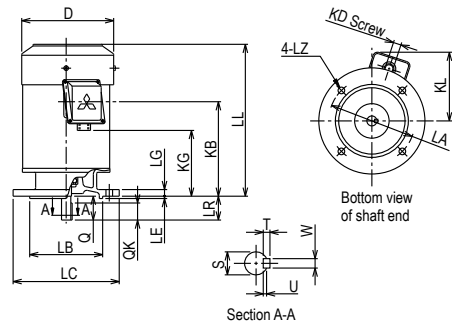

Outline Drawing



Specifications

Output Power HP (kW)	1 (0.75)
Phase	3 Phase
Pole	6 Pole
Frame Number	90L

Degrees of Protection	IP 55
Enclosure Construction	Totally-enclosed Fan-cooled
Thermal Class	Class F (155 °C)

Alignment	Vertical
Frame Material	Steel plate

Power Transmission	Direct-couple or Belt Driven
Direction of Rotation	Counterclockwise (CCW) viewed from shaft-end side

Connection Type	Terminal Block (6 Leads)
Coating Colour	Munsell N5.5 (Gray)
Conformed Standard	IEC 60034-1 & JEC-2137-2000

Voltage & Frequency	LT Type
	220/380~415V 50Hz 220/440V 60Hz

Motor Characteristics

Type	Hz	V	50% Load			75% Load			100% Load				Torque(%)		Is (A)	Inertia GD ² (kg-m ²)	
			(A)	Eff(%)	PF(%)	(A)	Eff(%)	PF(%)	(A)	Eff(%)	PF(%)	Speed (r/min)	Torque (kg-m)	Ts			Tm
LT	50	220	2.79	0.71	0.50	3.15	0.76	0.62	3.60	0.78	0.70	940	0.78	278	252	18.5	0.030
		380	1.61	0.71	0.50	1.82	0.76	0.62	2.08	0.78	0.70	940	0.78	278	252	10.7	
		415	1.75	0.68	0.44	1.91	0.74	0.55	2.12	0.77	0.64	950	0.77	335	302	11.6	
LT	60	220	2.44	0.73	0.55	2.85	0.78	0.66	3.38	0.79	0.74	1130	0.65	226	215	15.4	0.030
		440	1.55	0.68	0.47	1.70	0.74	0.59	1.92	0.77	0.67	1150	0.64	306	294	10.3	

Dimensions (mm)

Flange Number	Motor							
	D	LA	LB	LC	LE	LG	LL	LZ
FF165	186.3	165	130 j6	200	3.5	12	288.5	12

Terminal Box			Shaft End						
KD	KG	KL	LR	Q	QK	S	T	U	W
PF 3/4	133	156	50	50	40	24 j6	7	4	8

Bearing No.		Approximated Weight (kg)	Approximated Packing Dimensions (LxWxH)	Gross Weight (kg)
Drive End	Opposite			
6205ZZ	6204ZZ	21.5	425 x 280 x 226	22.5

Connection & Connection Diagram

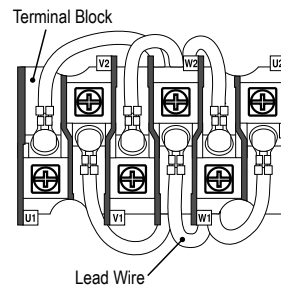

Connection

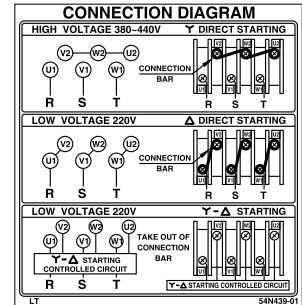

Connection Diagram

Circumstance Conditions

Ambient Temperature	-20 ~ +40°C
Ambient Humidity	95% RH or less
Operating Altitude	Less than 1,000m above sea level
Environment	No bursting / erosive gas or vapor